

---

**SEISMIC REHABILITATION OF HISTORIC CONCRETE STRUCTURE  
WITH FLUID VISCO-ELASTIC DAMPERS**

---

by

**Kit Miyamoto, M.S., S.E., President & CEO**

**Lon M. Determan, S.E., Project Manager**

**Amir Gilani, Ph.D., P.E., Project Engineer**

**Marr Shaffer & Miyamoto, Inc.**

**West Sacramento, CA**

**Robert D. Hansen, Ph.D., P.E., Professor Emeritus**

**University of Michigan**

**Walnut Creek, CA**

# **Seismic Rehabilitation of Historic Concrete Structure With Fluid Visco-Elastic Dampers**

***Kit Miyamoto, M.S., S.E., President & CEO  
Lon M. Determan, S.E., Project Manager  
Amir Gilani, PhD, P.E., Project Engineer  
Marr Shaffer & Miyamoto, Inc.  
West Sacramento, CA***

***Robert D. Hansen, PhD, P.E., Professor Emeritus  
University of Michigan  
Walnut Creek, CA***

## **Abstract**

This paper presents the nonlinear seismic analysis, development, and implementation of an innovative seismic retrofit strategy for a six-story nonductile reinforced concrete 145,000-sf (13,470 m<sup>2</sup>) historic building. Dynamic and nonlinear static analytical results verified that the building had a weak soft-story with inadequate post-yield capacity, and large torsional response. The analysis indicated that the existing building is not seismically adequate to withstand anticipated lateral forces generated by earthquake excitations at the site. A “collapse prevention” performance upgrade for a 475-year return event was desired. Nonlinear fluid viscous dampers were placed at the first story level to reduce the seismic demand and obtain a more uniform response. Visco-elastic fluid viscous dampers were strategically placed at one side of the building to reduce the torsional irregularity of the building. The proposed cost effective, state-of-the-art retrofit will improve the seismic performance of the building.

## **Introduction**

This paper presents the performance-based evaluation and retrofit design of the Hotel Stockton. The 145,000-sf (13,470 m<sup>2</sup>) reinforced concrete building, built in 1910 in Stockton, California, is a torsionally irregular structure comprised of a six-story portion connected to a two-story portion. There was significant concern that the building will not be able to withstand the level of earthquake shaking expected at the site for two reasons: a weak and soft lateral force resisting system at the first floor level, and the inadequate confinement of reinforcement in the first story columns. To assess the performance of the structure, a detailed mathematical model of the building was prepared based on FEMA 273 guidelines. Dynamic and nonlinear static analytical results verified the presence of the soft-story response, inadequate post-yield capacity, and large torsional response. The analyses indicated that the existing building is not seismically adequate to withstand anticipated lateral forces generated by earthquake excitations at the site. The existing structure will suffer substantial damage and possible collapse in the event of a major earthquake.

To address the above-mentioned inadequacies, the Owner decided to undertake a voluntary seismic upgrade of this building. The focus of the seismic rehabilitation was to address the major deficiencies of the structure, namely the soft-story and torsional response of the building. The main objective was to provide a “collapse prevention” performance goal during a 475-year return event. Nonlinear fluid viscous dampers were placed at the first story level to reduce the seismic demand and obtain a more uniform response. Visco-elastic fluid viscous dampers were strategically placed at one side of the building to reduce the torsional irregularity of the building. Finally, the first story interior columns supporting the six-story portion of the building were wrapped with a fiber-reinforced polymer composite (FRP). A new mathematical model was prepared incorporating the seismic upgrades, and was subjected to nonlinear time history analyses using three sets of two-component, independent acceleration histories derived from a site-specific acceleration spectrum. Evaluation of the analytical results of this model showed that the story drift for the first floor was significantly reduced, the torsional response was nearly eliminated, and all structural members remained elastic.

## Description of Structure

The Hotel Stockton, built in 1910 as a 252-guest room hotel, is a historic landmark building in Stockton, California. The building, also referred to as *The Stockton*, measures approximately 300 ft (91.4 m) in the

E-W direction and 100 ft (30.5 m) in the N-S direction. In elevation, it is comprised of a six-story portion on the east side and a two-story portion on the west side, and has a full basement. The first story is 18 ft (5.5 m) high and the remaining floors have a story height of 10'-3" (3.1 m). Figure 1 below shows a south elevation of the eastern portion of the building.

In the E-W direction, the building consists of 15 bays at approximately 20-ft (6.1-m) spacing. In the N-S direction, there are five bays at approximately 20 ft (6.1 m) per bay, see Figure 2. The structure is a cast-in-place reinforced concrete building. Reinforced concrete columns, beams, and shear walls comprise the gravity and lateral load resisting system. The basement columns are 18- and 20-in. (457 and 508 mm) square for the two-story and six-story segments of the building, respectively. At the ground floor and above, column sizes vary from 18-in. (457 mm) square at the first story to 14-in. (356 mm) square at the fifth story. There is a full 9-in. (229 mm) thick concrete perimeter wall between the basement and the first floor, and there are numerous 6-in. (152 mm) thick concrete walls between the floors above the second floor. However, there are no structural walls between the ground and the second floor levels. Typical floors consist of 4-in. (102 mm) concrete slabs with a 2-in. (51 mm) topping slab supported by E-W concrete beams, and N-S concrete girders.

Although the as-built plans of the structure are not available, field investigations have shown that the

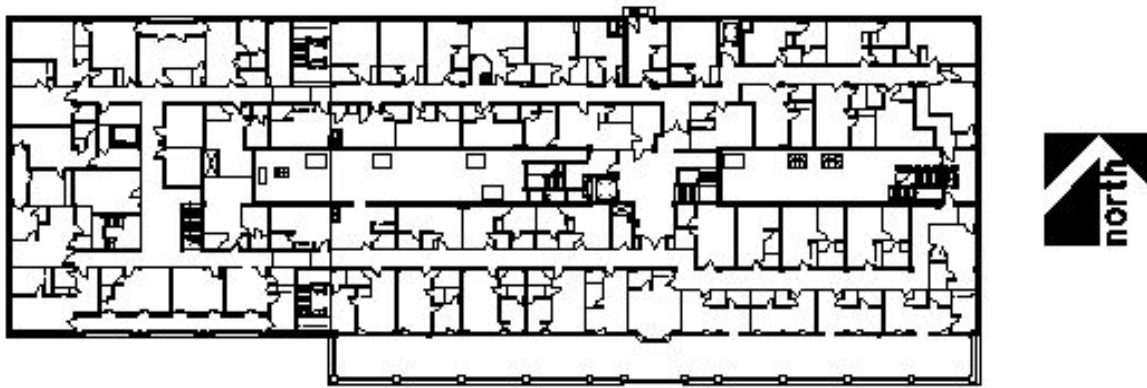

**Figure 1: South Elevation**

columns typically have four and eight longitudinal reinforcing bars around the perimeter of columns at the two-story and six-story segments, respectively. Typical minimum concrete cover for the reinforcement is approximately 2 ½ to 3 in. (64 to 76 mm). The ground-to-first story columns have eight 1-in (25 mm) square bars. Typical transverse ties consist of 1/8-in (3.2 mm) thick by 1-in (25 mm) wide bars at 8 in. (203 mm) spacing.

MPa), per FEMA 273. A yield value of 36 ksi (250 MPa) was used for the column ties.

- *Frame elements.* All columns were modeled as square sections with longitudinal bars in a circular pattern. Girders and beams were modeled as rectangular sections with the section depth measured from the top of the topping slab. T-beam action from the floor slab was neglected. All dimensions were specified as centerline-to-centerline – (i.e. no rigid end offsets were specified). The perimeter basement walls and wall segments between the floors were



**Figure 2: Plan View at 2<sup>nd</sup> Floor**

### Analytical Model of Existing Structure

The computer program ETABS (CSI 2001) was used to prepare a mathematical model of the building, see Figure 3 for a schematic of the model. Key features of the mathematical model are summarized below.

modeled as shell elements. Similarly, the floor slabs at all levels were modeled as shell elements. FEMA 273 recommends using a value of 50% of the gross moment of inertia ( $I_g$ ) for the cracked moment of inertia ( $I_{cr}$ ) of the flexural members. This reduction factor was applied to the beams, columns and shearwalls.

- *Material properties.* A concrete compressive strength of 3 ksi was used. This value is consistent for concrete strength of buildings constructed in the early part of the last century (FEMA 273), and corresponds to the values obtained from field investigations. Tensile testing of sample reinforcement indicated yield and tensile strengths of approximately 65 and 72 ksi (450 and 500 MPa), respectively. Field studies indicated that the column longitudinal reinforcement splice lengths varied from 26 to 28 inches (660 to 711 mm) for 1-in (25 mm) square bars. Therefore, the yield properties of the longitudinal bars were reduced to 42 ksi (290
- *Parameters for nonlinear analysis.* For this soft-story structure, the nonlinear behavior will be entirely limited to the first story columns. As such, nonlinear hinges were defined and placed on these columns. To capture the complete nonlinear response of these columns, two types of hinges were used: shear hinges placed at mid-height of the columns, and biaxial-force (PMM) hinges near the top and bottom of the columns. The location of the PMM hinges was determined by assuming that the plastic hinges would form at a distance of  $2b/3$  (where “b” equals the width of the column) from the top and bottom of column-to-floor connections. For the PMM hinges, interaction curves based on ACI

318-99 were used to determine the axial force-biaxial moment yield surface. For the nonlinear analysis, the column plastic hinge properties are a function of column slenderness, transverse reinforcement (size, spacing, and anchorage), and axial and shear demand. For the columns under consideration, the axial force ranges between 10-15 percent of the nominal compressive strength, and flexure is the controlling response. The shear force is less than three times the nominal shear strength, and the columns have poor confinement (transverse reinforcement). Since the lap splices for the longitudinal reinforcement are not fully developed, sudden strength degradation may occur after the onset of the nonlinear behavior. Therefore, hinge formation (yielding) should be avoided, and subject

columns should remain elastic.

- *Gravity loading.* Gravity loads used in the model consisted of the self-weight of the structure, 0.02 ksf (0.96 kPa) for partitions, 0.025 ksf (1.20 kPa) for weight of the 2-in. (50-cm) topping slab, and 0.005 ksf (2.40 ksf) for miscellaneous (e.g., fans, vents, plaster). Live loads consisted of typical code prescribed floor loads.
- *Inertial mass.* The mass of the structure consisted of all structure dead loads and one half of the partition loads. The code-mandated 5-percent eccentricity was achieved by offsetting the floor mass. The total inertial weight (mass) of the structure is approximately 14,000 kips (64,050 kN).

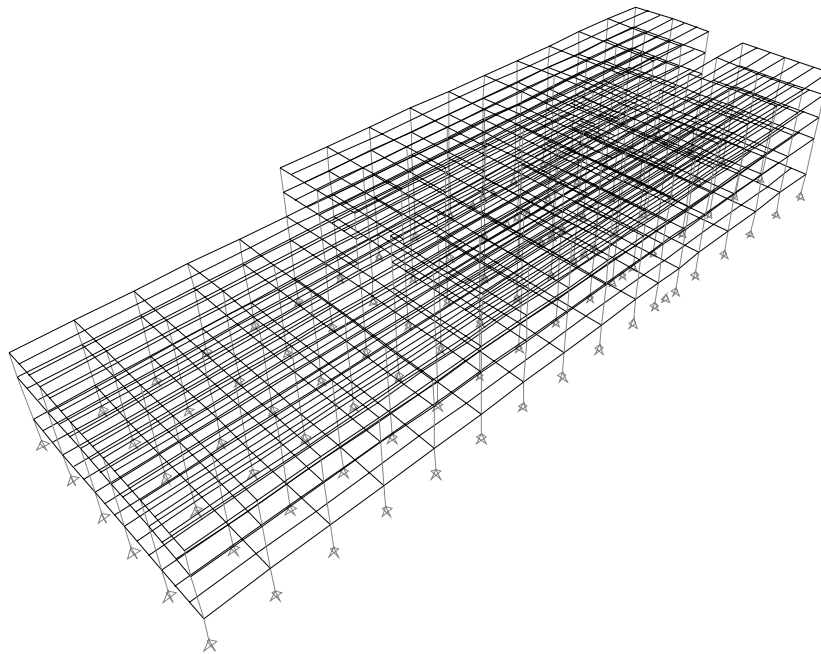
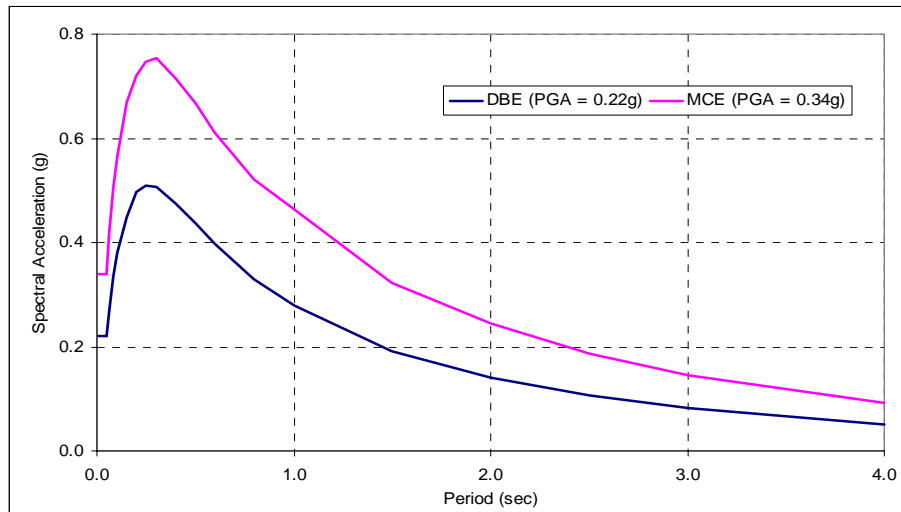

**Figure 3: Schematic of The Mathematical Model of The Building**

## Earthquake Histories

Site investigations were used to determine the site-specific acceleration spectra. The Design Basis Earthquake (DBE) spectra (10% probability of

from the horizontal components of each of the three recorded earthquake records to the target spectra, and then base-line correcting in the time domain. The records were derived from the 1989 Loma Prieta earthquake (0- and 90-degree components recorded at

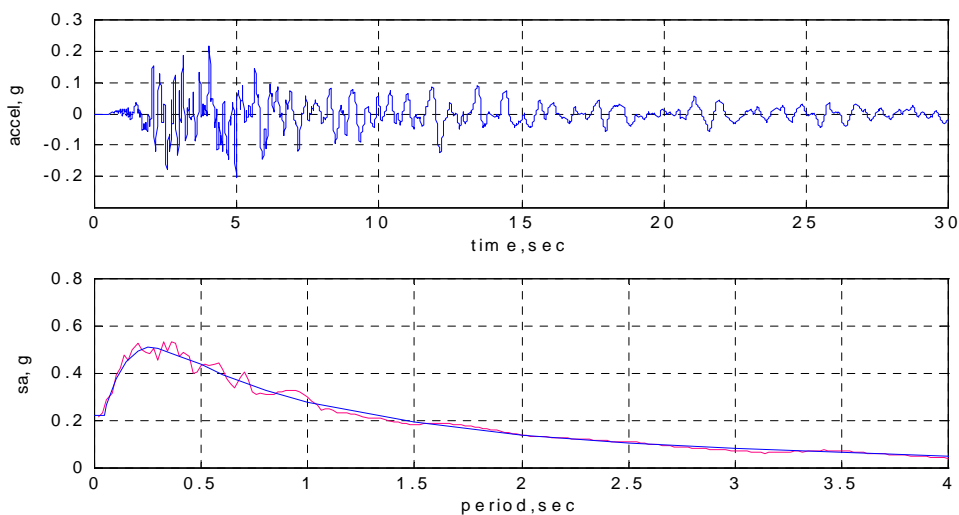

**Figure 4: Response Spectra**

exceedence in 50 years) used for the studies presented herein is shown in Figure 4. In the same plot, the response spectrum for the Maximum Considered Earthquake (MCE) (2% probability of exceedence in 50 years) is also shown.

Three sets of time histories were prepared by J. P. Singh (Singh 2002) by matching the response spectra derived

Agnews, 0- and 90-degree components recorded at Gilroy, and 270- and 360-degree components recorded at San Marino). Figure 5 shows the DBE acceleration record and the computed acceleration spectrum for the x-component of the Agnews record. The y-component of this record and the x- and y-components of the other two records have similar acceleration spectra.



**Figure 5: Acceleration Record & Spectrum**

## Analytical results of the existing building

*Dynamic analysis.* A modal analysis of the building was conducted to determine the fundamental period and mode shapes of the structure. Table 1 summarizes the results for the first three modes obtained. The first two mode shapes of the building are shown in Figure 6a and 6b. It is noted that the response is that of a soft-story structure with nearly all the deformation concentrated in the first story columns.

**Table 1**

Mode	Period (sec)	Principal direction
1	1.2	Transverse (N-S)
2	1.0	Longitudinal (E-W)
3	0.9	Torsion

torsional component to this mode. In particular, the largest deformation occurs at the far right (east) side of the building. This torsional response will place additional demand on the columns at this side of the structure.

*Nonlinear pushover analysis.* To assess the performance of the building to seismic loading, a nonlinear static analysis was conducted. The structure was initially loaded to a gravity loading equal to 110% of the dead load and 27.5% of the unreduced live load. Next, step-by-step lateral loading in the x- and y- directions were applied to the structure. Two separate and independent lateral load patterns were considered: (1) a force pattern matching the mode shapes with 100% and 30% loading in each direction and (2) uniform force pattern with 100% and 30% loading in each direction. For the

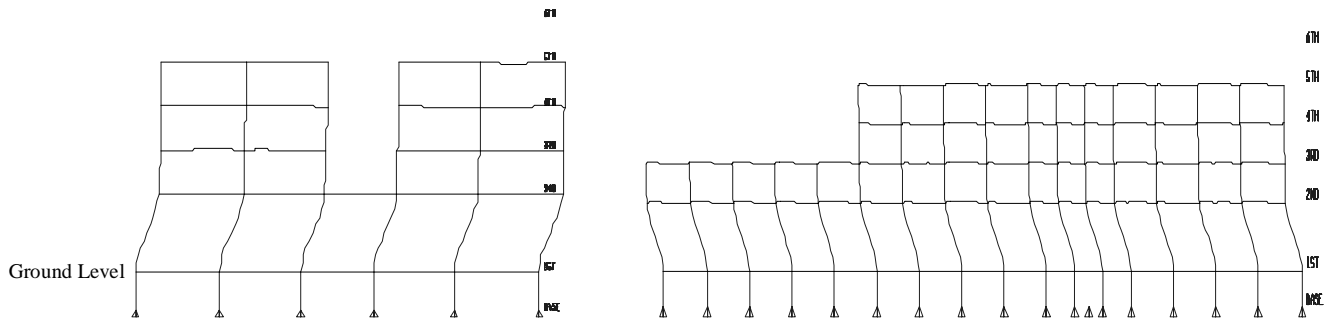

**Figure 6: Modes 1 & 2 (Elevations)**

Figure 7 shows the deformed shape of the second floor in plan for the first mode. It is noted that due to the lack of symmetry in the N-S direction, there is a large

governing load case, the demand and capacity curves do not intersect. Therefore, collapse of the structure is predicted.

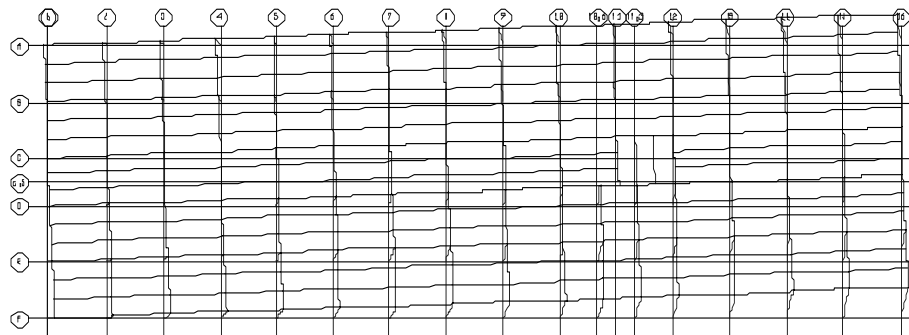

**Figure 7: Mode 1 (Plan)**

Two particular events of interest were studied: (1) when does the first plastic hinge form in each direction, and (2) what is the ultimate configuration of the plastic hinge? (The plastic hinges are identified by circles on the columns.) The displaced shape of the structure at the formation of the first column plastic hinge is shown in Figure 8. The frame elevation on the left corresponds to

The displaced structure at a story displacement of 1.5 in. (38 mm) for loading along the longitudinal-axis (Figure 9a), and 2.5 in. (64 mm) for loading along the Transverse-axis are shown (Figure 9b). Note that many of the first story columns have formed plastic hinges at the top and bottom. The soft-story behavior of the

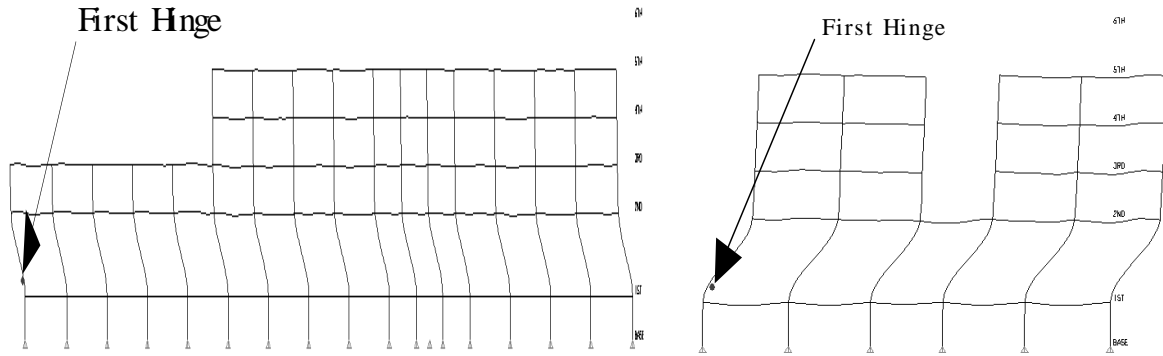

**Figure 8: Hinge Initiation**

the formation of the first plastic hinge when the structure is pushed along the longitudinal-direction. This yielding

building is made clear in the figures; all the floors above the second floor have a nearly rigid behavior, while the

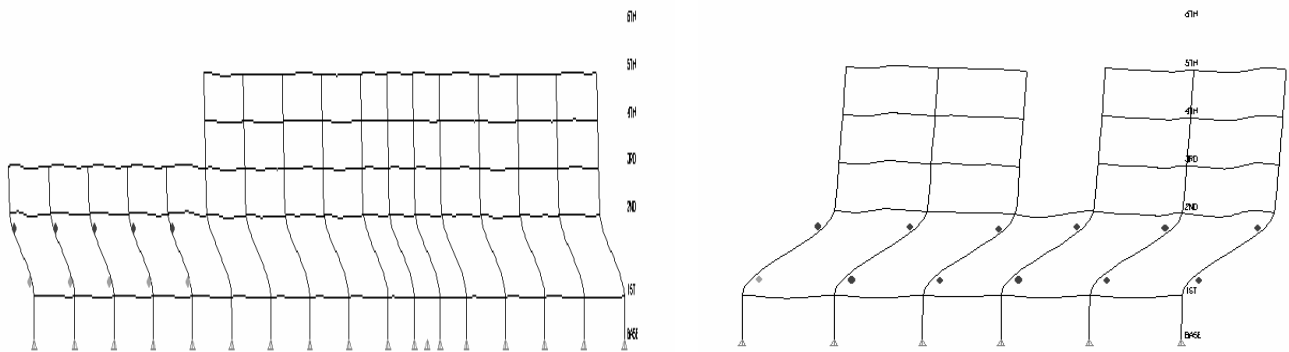

**Figure 9a & 9b: Progressive Hinge Formation (elevations)**

response occurs at a displacement of 0.84 in. (21 mm), measured at the second floor level. The frame elevation on the right corresponds to the formation of the first plastic hinge when the structure is pushed along the transverse-direction. This yielding response occurs at a displacement of 1.44 in. (37 mm), measured at the right (east) side of the second floor level. In summary, as long as the second floor displacements are limited to the values specified above, it is expected that the column response for the critical first story columns will remain in the elastic range.

first story columns experience substantial deformation.

Figure 10 shows the second floor plan view of the structure at the deformation level of 2.5 in. (64 mm) as the structure is pushed in the transverse-direction. It is noted that all the nonlinear behavior is concentrated at or close to the right (east) side of the building. As previously noted, the building is torsionally irregular in the transverse direction.



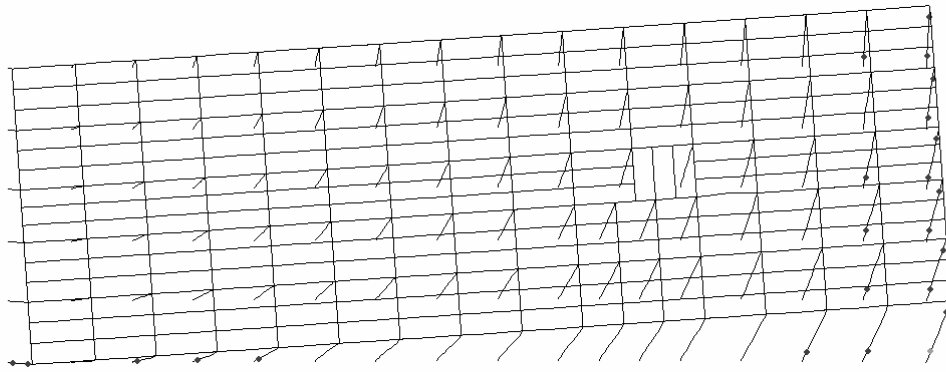

**Figure 10: Progressive Hinge Formation (Plan)**

*Linear time history analyses.* To investigate the performance of the building during a 475-year return event (DBE), the structure was subjected to acceleration time histories. Study of the three motions revealed that the San Marino record produced the most severe test for the structure (i.e., the largest values of column stress and story drift). As such, this record will be used for the remainder of this paper for comparison purposes.

The three dimensional linear model was subjected to this accelerogram. Figure 11 shows the second floor displacements as measured at the lower-right (S.E.) corner of the building. Using equal displacement assumption, a comparison of the time history response of the existing building with that of the nonlinear pushover analysis indicates that the story drifts will cause significant plastic rotation in the hinge regions of the columns, and cause probable collapse of the building.

*Performance Goal.* Since this is a voluntary seismic upgrade, the focus of the seismic rehabilitation is to address the major deficiencies of the structure, namely, the soft-story and torsional response of the building. The retrofit will limit the response of the structure to linear elastic behavior; that is, limiting the maximum x- and y-components of the second floor displacement to 0.85 in. (22 mm) and 1.44 in. (37 mm), respectively. This will give an adequate level of confidence against collapse of the structure. The main performance goal is to provide a cost-effective “collapse prevention” performance upgrade during a 475-year return event (DBE).

### **Retrofit method**

To meet the selected performance goals for the upgrade

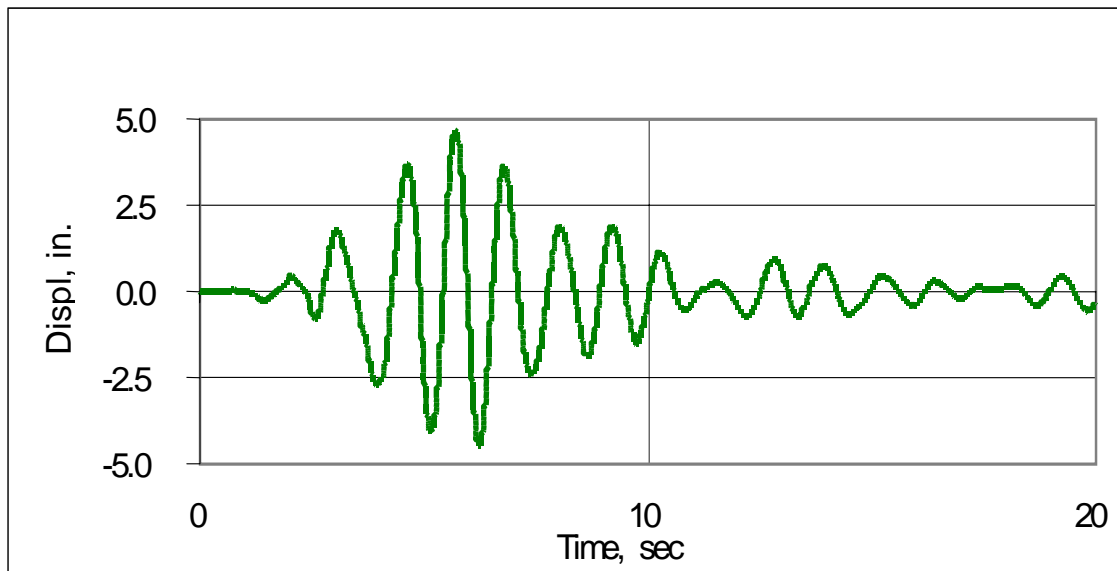

**Figure 11: Displacement History of Existing Structure (Linear Model)**

of this structure, a retrofit approach combining several state-of-the-art strategies was utilized.

1. Reduce the soft-weak story effects by increasing the effective damping of the structure. This objective was achieved by employing Fluid Viscous Dampers (FVD) at the first floor.
2. Reduce the torsional response of the building without increasing acceleration demand of the super structure. This was achieved by adding fluid visco-elastic dampers at the east side of the structure.
3. Provide a more redundant story shear capacity in the upper floor transverse direction. In the transverse direction, the building has structural walls at the exterior walls only. Therefore, wood shear walls were added for the upper six story portion of the building. These walls will act in a fashion analogous to cross-walls in an unreinforced masonry (URM) bearing wall building.
4. Provide redundancy for the gravity load-carrying capacity of the columns along the right (east) side of the structure. Addition of steel columns for the FVD braces adjacent to all the columns along this gridline met this goal.
5. Increase ductility of all the interior first story columns for the 6-story segment of the building. To meet this criterion, fiber-reinforced polymer composite (FRP) was wrapped around the hinge regions (top and bottom) of the columns.

## Structural upgrade

FVDs have been extensively researched (Constantinou and Symans, 1992) and implemented in the upgrade of many structures, including the seismic retrofit of the historic Hotel Woodland (Miyamoto and Scholl 1996). FVDs provide an economical way of improving the structural response without losing any floor space. This was the chosen seismic improvement method for this building for two reasons: (1) it reduces the second floor displacement by increasing viscous damping, and (2) it reduces the seismic demand of the superstructure.

*Damper selection.* FVDs were strategically placed in the structure to optimize their effectiveness without blocking access to the architecturally sensitive areas of the ground floor. A total of 20 damper bays were utilized. Initially, only linear fluid viscous dampers

were considered for the upgrade, however, this approach necessitated using relatively large devices to meet the performance criteria. In addition, this did not address the torsional irregularity of the building. To mitigate these problems, two types of devices were utilized: nonlinear fluid viscous dampers were used in 16 braced bays, and a combination of nonlinear fluid viscous dampers in parallel with elastic elements (herein referred to as fluid visco-elastic dampers, or FVEDs) was utilized in four braced bays. The table below summarizes the pertinent properties of the devices.

**Table 2: Damper Properties**

<i>Device</i>	<i>No.</i>	<i>DBE Capacity, kip (kN)</i>	<i>c, k-sec/in (kN-sec/mm)</i>	$\alpha$	<i>K, k/in (kN/mm)</i>
FVD	16	210 (934)	100 (35)	0.5	None
FVED	4	300 (1334)	125 (44)	0.5	144 (50)

Additional columns at either end of the diagonal devices will prevent the transfer of the damper forces to the existing building columns. Figure 12 shows a typical damper frame elevation.

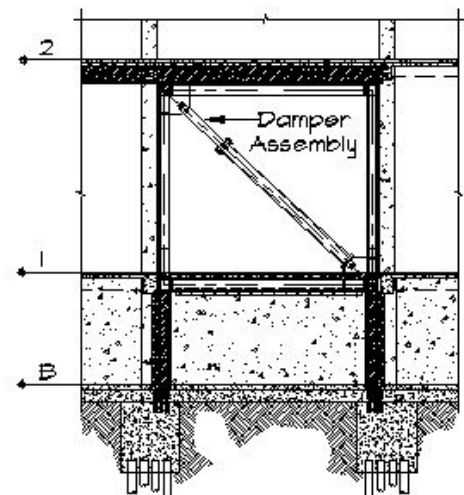

**Figure 12: Damper Frame Elevation**

## Fluid Visco-Elastic Damper

A combination of fluid viscous dampers and polyurethane elastomers have been successfully used in the aerospace industry. The mechanical characteristics of this elastomer are as follows: (Gallagher Corporation, 2002)

1. Urethane Elastomers provides consistent mechanical properties through a temperature range of 0°F to 225°F (-18°C to 107°C).
2. Urethane exhibits compressive capacity of 80 ksi (552 MPa) without molecular damage and elasticity.
3. Aging under static stress has no effect on mechanical properties if protected from ultraviolet light.
4. Flame resistance is sufficient to meet Federal Aerospace Regulation 25.853B.

See Figure 13 for FVED and FVD construction. Prototype testing per FEMA 273 will be conducted to verify response and durability.

incorporating the dampers were performed. The mathematical model of the existing building was modified by adding the sixteen FVEDs and the four FVEDs. Two time history cases were considered. In one case, the mathematical model was preloaded by a static load equal to 90% of the total dead load prior to being subjected to the lateral accelerations. In the second case, the preload equaled 110% of the dead load and 27.5% of the unreduced live load. The envelope of response quantities was then obtained by selecting the maximum values from the two load cases.

*Response evaluation.* To evaluate the seismic response of the upgraded structure, the displacement response of the second floor was examined and a stress check of all

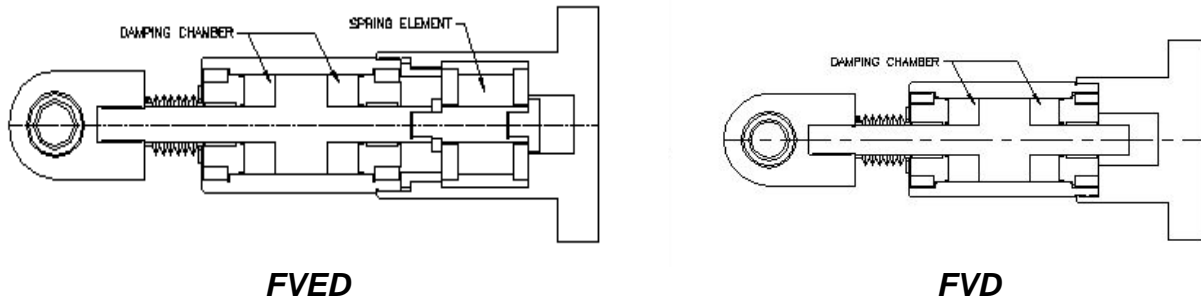
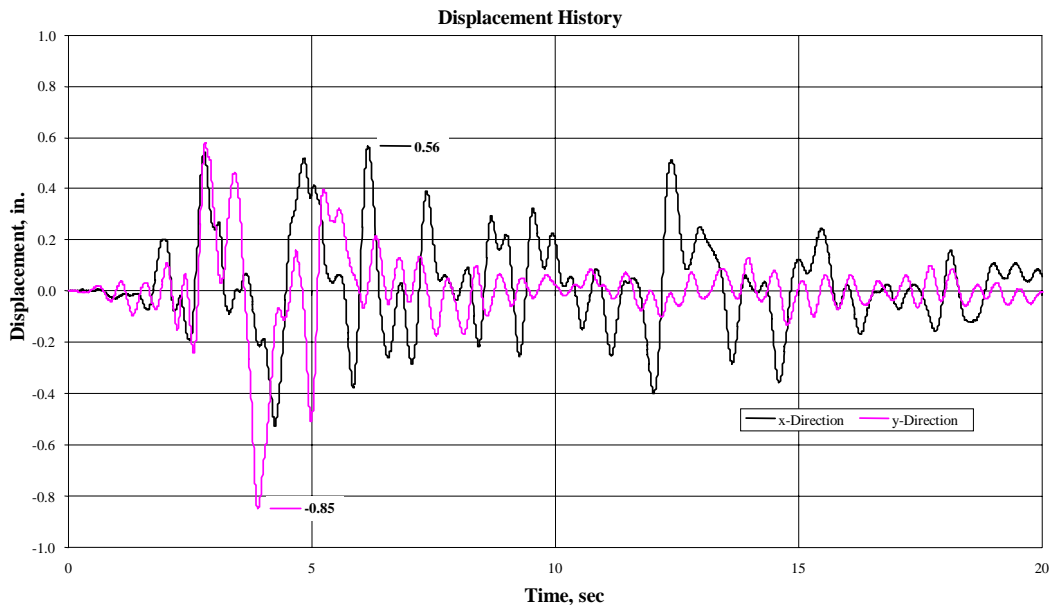

**Figure 13: FVED & FVD Devices**

### Response of the retrofitted structure

To assess the effectiveness of the proposed building upgrade, nonlinear time history analyses of the structure

first story columns was performed. Figure 14 shows the second floor displacement responses for the lower-right (S.E.) corner. It is noted that the maximum computed displacements are approximately 0.56 in. (14 mm) and

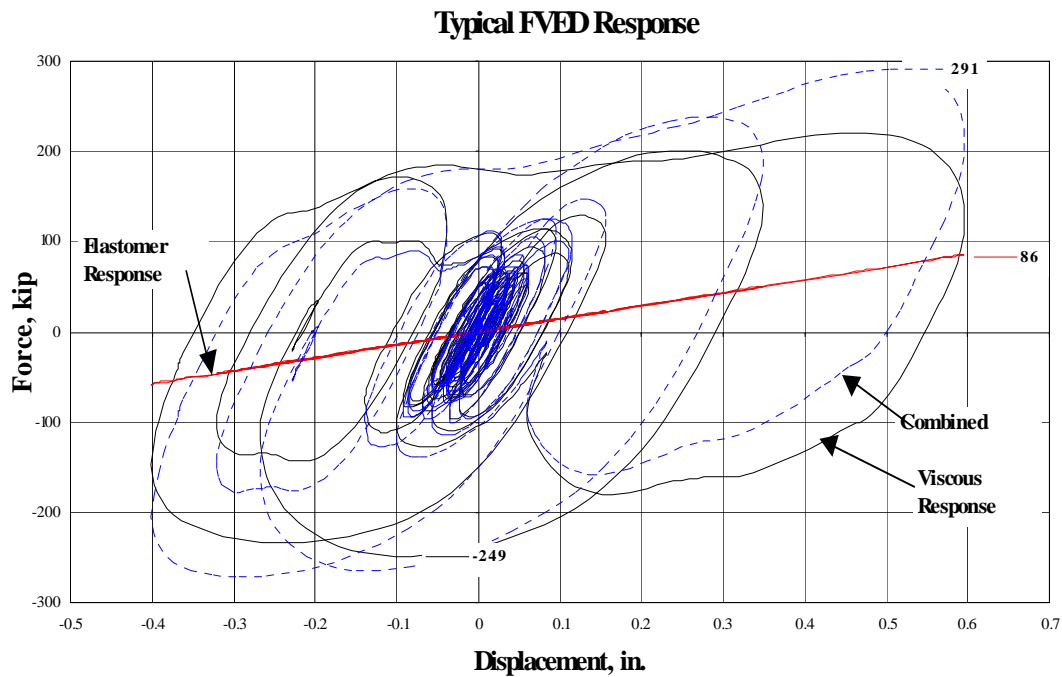

**Figure 14: Displacement History of Damped Structure**

0.85 in. (22 mm) in the longitudinal transverse directions, respectively, which is well below their target values. This corresponds to story drift ratios of approximately 0.003 and 0.004, respectively. A comparison of the displacement response for the original structure and this figure shows that the maximum response was reduced by more than a factor of five by the addition of FVD and FVED elements.

Finally, the computed axial force in the columns was examined. No net axial tension was found in the existing columns. The maximum force in the FVD was less than 200 kips (890 kN). As such, the 200-kip (890 kN) dampers used are adequate for these 16 damper

structure was upgraded with a combination of sixteen nonlinear fluid viscous dampers, four nonlinear fluid visco-elastic dampers, and fiber reinforced polymer wrap at selected columns. The analytical studies predict that the retrofitted structure will have a significantly improved performance when compared to the existing structure. In particular, the upgrade will limit the response of the existing members to the linear range by limiting the expected seismic demand on the structure. This upgrade will reduce the risk of building collapse. Total seismic upgrade cost was \$1.3 million (\$9/ft<sup>2</sup>, \$96/m<sup>2</sup>), which was about 5% of total construction budget (\$24 million, \$165/ft<sup>2</sup>, \$1780/m<sup>2</sup>).



**Figure 15: Typical FVED response**

bays. Figure 15 depicts the response of a typical FVED. It is noted that the maximum damper and spring forces are approximately 250 kips (1112 kN) and 90 kips (400 kN), respectively. Spectra acceleration of this structure was 0.17g.

## Conclusion

Analytical studies of the Hotel Stockton revealed that the structure would not be able to withstand the seismic loading resulting from the anticipated site-specific earthquakes. To mitigate this seismic deficiency, the

## References

- Computer and Structures, Inc., 2002, "ETABS 7.2.2, Linear and nonlinear static and dynamic analysis and design of building systems," Berkeley, CA
- FEMA 273, October 1997, "NEHRP Guidelines for the Seismic Rehabilitation of Buildings," Building Seismic Safety Council, Washington, D.C.
- Miyamoto, H.K. and Scholl, 2002, "Seismic Rehabilitation of an Historic Non-Ductile Soft-Story Concrete Structure

using Fluid Viscous Dampers,” Proceedings of the 11th World Conference on Earthquake Engineering

Constantinou, M. and Symans, M., 1992, “Experimental & Analytical Investigation of Seismic Response of Structures with Supplemental Fluid Viscous Dampers,” State University Of New York at Buffalo, Buffalo, New York, NCEER-92-0032

Sing, 2002, Site Specific Time Histories for Hotel Stockton, Richmond, CA

Gallagher Corporation, 2002, “The Engineering Properties of Urethane Elastomers,” Gurnee, IL