

## CRANE AND INDUSTRIAL BUFFERS

**Taylor Buffers** are fluidic type shock absorbers designed for heavy duty, severe service applications. They absorb the total impact energy of the application and convert this energy to heat. After impact, internally mounted coil springs gently restore the buffer to its original un-stroked condition.

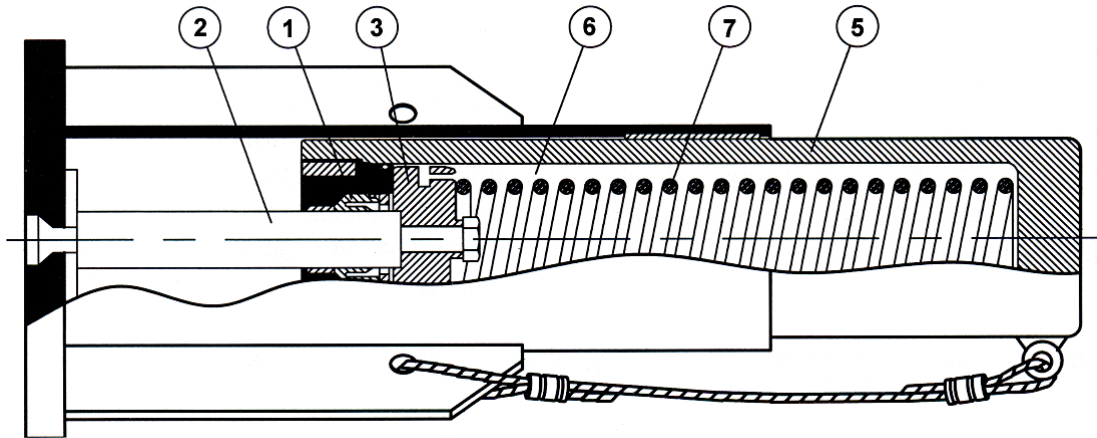

A few reasons why Taylor Buffers are so highly respected with world-wide acceptance:

1. Patented Taylor Mechanical-Growth Seals, machined from Teflon bar stock. Low cost packings and O-Rings aren't good enough for Taylor quality. The Taylor Seal is the same seal used in Taylor Fluidicshoks® and Liquid Die Springs and meets rigid NASA specifications.
2. Solid Stainless Steel Piston Rod for the ultimate in high strength and corrosion protection.
3. Patented fluid amplified ORVIS head yields the smoothest, most consistent output curves of any shock absorber. No dangerous force spikes or steps as found in conventional metering systems. Output force varies with impact velocity to assure safe, smooth deceleration at any speed. Output efficiency is 90% of a square wave, yielding minimum decelerations at all times. All standard Taylor Buffers are custom orificed for each individual application and are ready to bolt in and operate with no adjusting or tuning required.
4. All buffers are available with optional full drive down capability for use of buffer stroke as end approach (full drive down is not recommended for cranes subject to impact with power-on).
5. One piece cylinder machined from solid high strength steel bar stock on most sizes. No leaky fatigue-prone welds as found in other shock absorbers.
6. All Crane and Industrial Buffers use energy absorbing Tayco Piezoil as fluid. This non-flammable fluid is permanently sealed in the buffer cartridge and requires no replenishing or refilling over the life of the buffer.
7. Coil spring return 100% internal to unit. All springs are contained within the one piece cylinder putting solid steel between you and the return mechanism. Safety cables are standard at no additional cost as an added safety feature, and are required by law for overhead applications.
8. Standard buffers meet -40°F to +160°F ambient specifications. More rigorous requirements can be met on an optional basis.
9. For overhead crane service Taylor Buffers exceed both rigid A.I.S.E. energy absorption and deceleration specifications, and current OSHA requirements. Cranes can be protected at up to 100% speed.